

# CARUS

## Carotid 3D high frame rate ultrasound scanner for advanced diagnosis of cardiovascular disease

Dennis Koehn (CARIM)  
Margreet Docter (ErasmusMC)

Euripides project EUR-06.110

### Aims

The CARUS project aims at the development of early predictive and advanced diagnosis technology for **atherosclerosis** in the carotid artery in response to the major health issues associated with cardiovascular diseases. The ultimate technological goal of the project is to develop an innovative high frame rate matrix **ultrasound** system for non-invasive real-time three-dimensional quantitative assessment of structural and functional vascular properties.

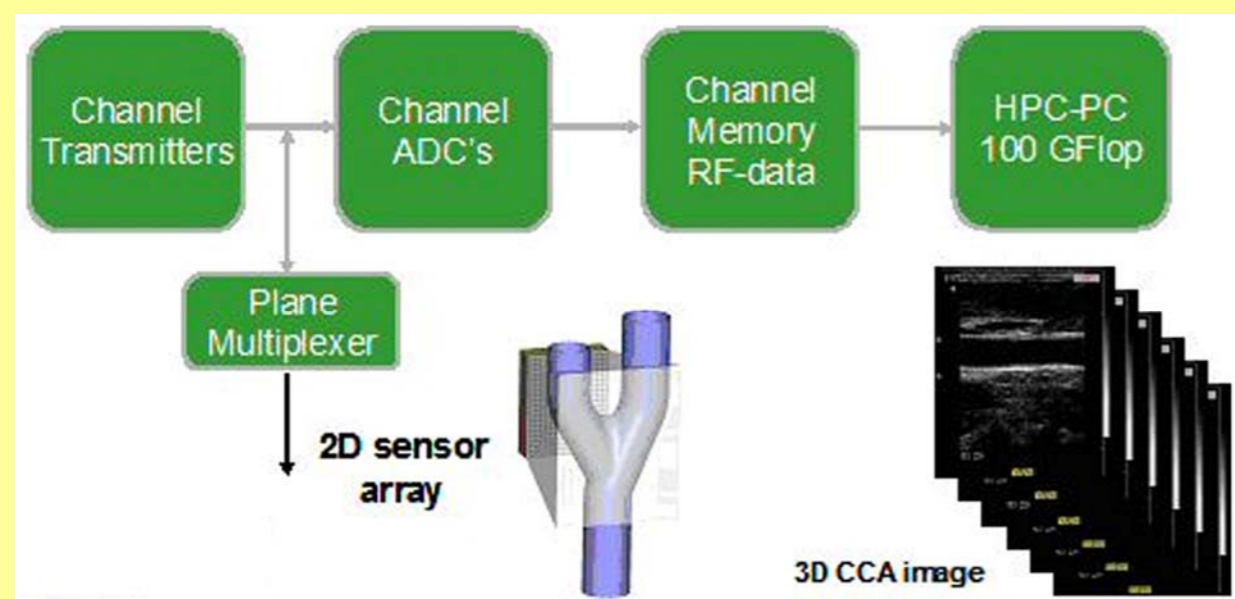

### Requirements

The project intelligently combines:

- A high-density matrix sensor,
- Integrated novel package of imaging electronics,
- High frame rate 3D ultrasound beam forming,
- Specialized 3D software.

### Atherosclerosis

Cardiovascular diseases including stroke are the most important causes of mortality in the Western World. The cause of these diseases is atherosclerosis. Atherosclerotic plaques near the bifurcations of the carotids form the major cause of stroke. Coronary artery disease (causing e.g. a heart attack) and carotid vascular disease are strongly related. The carotid artery can be assessed with ultrasound much better than the coronary arteries.

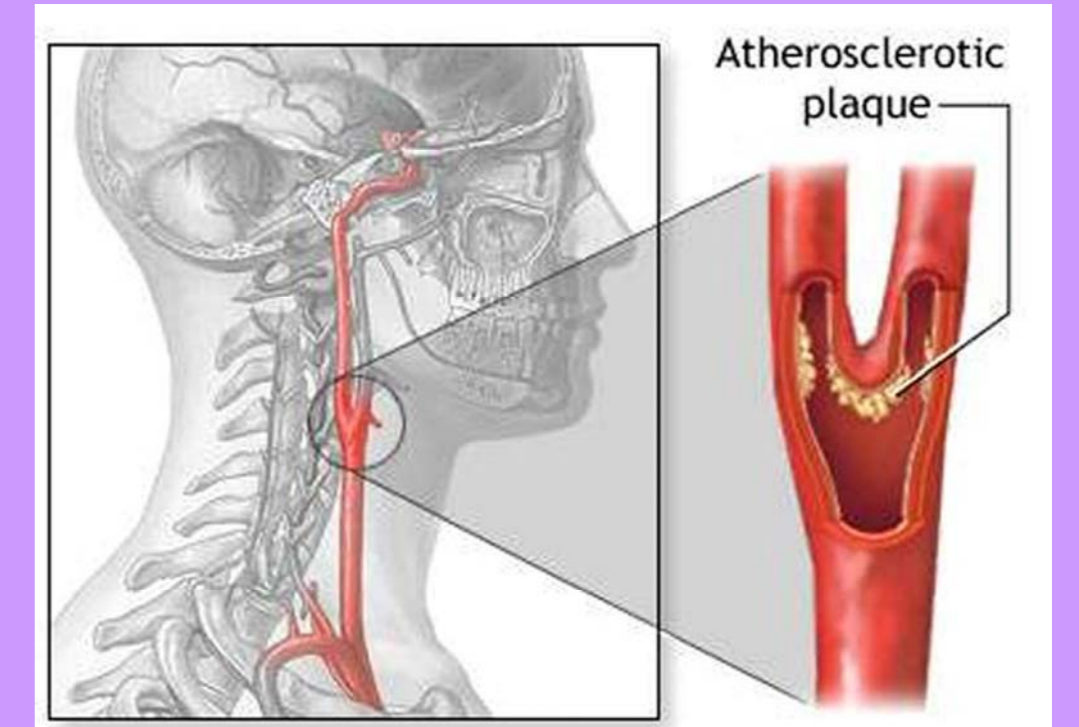

### 3D Ultrasound

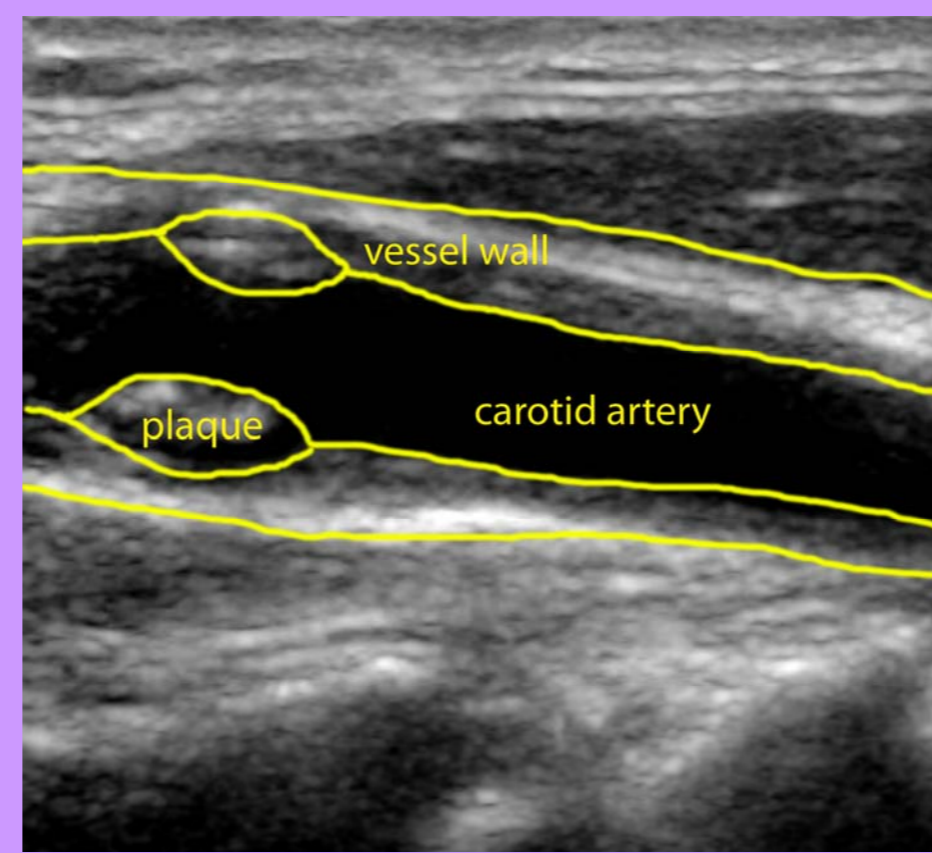

Ultrasound is the most widely used diagnostic technique for cardiovascular patients, because of its versatility, ease of use, cost effectiveness, reproducibility and patient's tolerance. The presence and properties of atherosclerotic plaques within a single plane of observation can be shown by two-dimensional (2D) ultrasound (US) imaging techniques.

However, the properties of a plaque, such as size, location and the presence of angiogenesis, can be presented in more detail, without out of plane motion, with three-dimensional (3D) ultrasound techniques allowing an early predictive and advanced diagnosis.

### Probe development

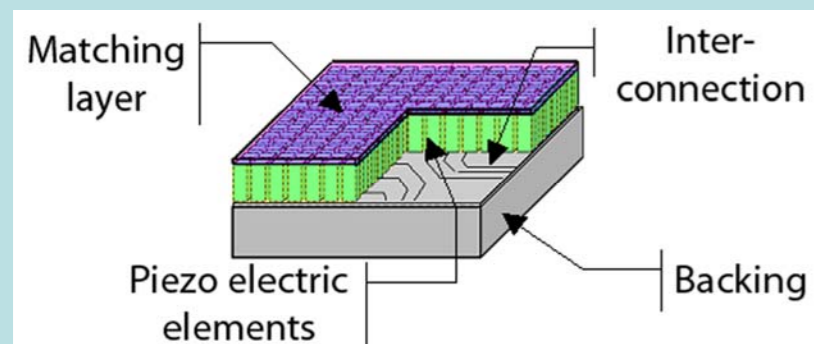

The 2D probe is developed by Vernon, Tours. It consists of 32 by 32 elements, sized 0.4 mm squared. The first prototype is ready and ErasmusMC (Rotterdam) is currently measuring the impedance and pulse echo response.

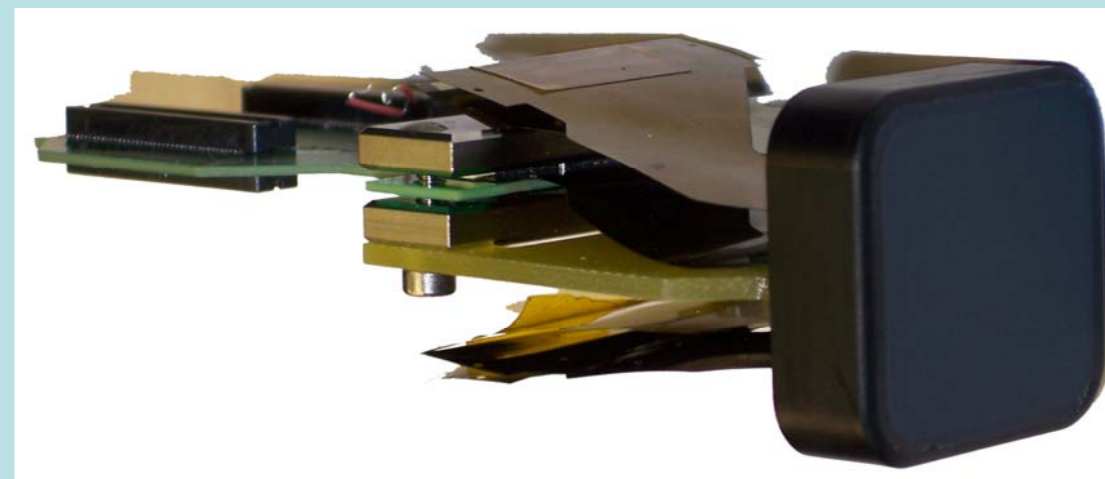

### Electronics

The matrix probe will be connected to a 128 channel transmitter/ receiver system. Addressing 1024 elements means requires complex switching/multiplexer electronics. ErasmusMC designed the interfacing electronics. Esaote (Maastricht) will physically realize this design and Vernon takes care of the interconnect between probe and electronics.

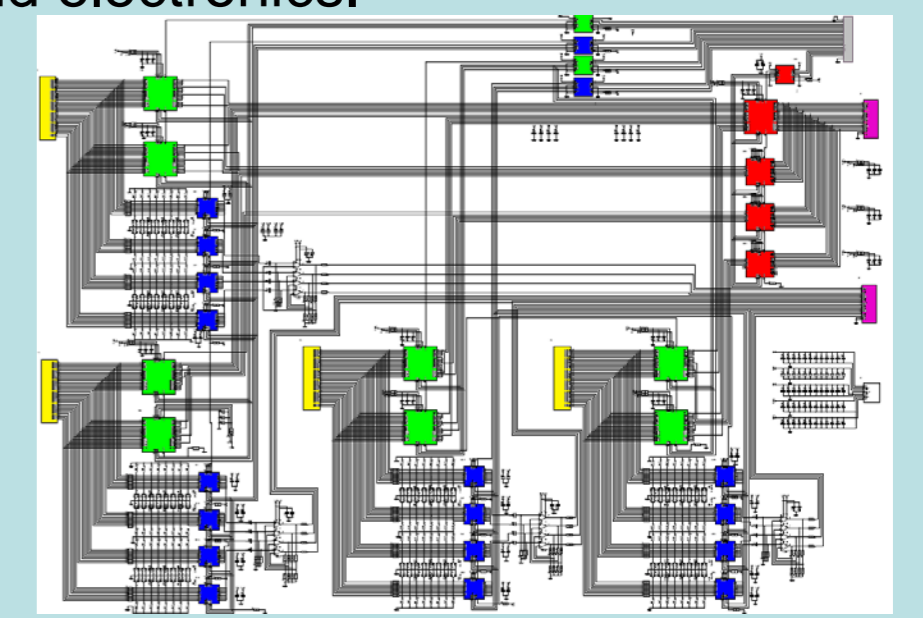

### Image segmentation

Pie Medical (Maastricht) has already realized the segmentation of 2D images along the vessel, intima media thickness is found and measured. The current challenge is to perform image segmentation in 3D.

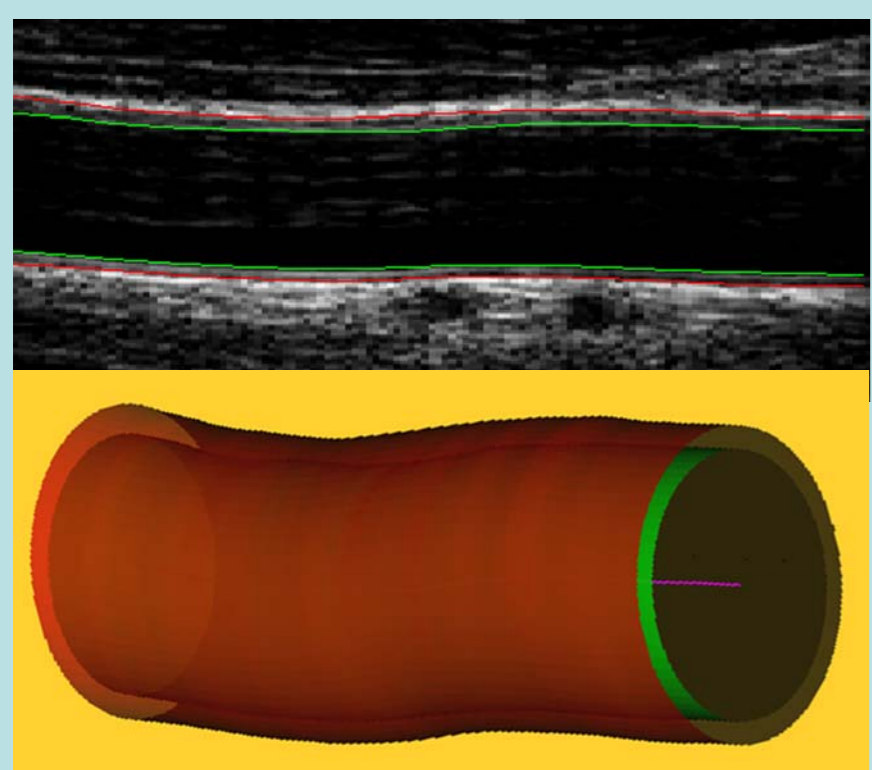

### Clinical testing

Clinical testing of the CARUS probe will take place in HEGP (Paris) and ErasmusMC. The future clinical research is targeting at disease of the arterial wall, biomechanics and pharmacology of large artery remodeling.

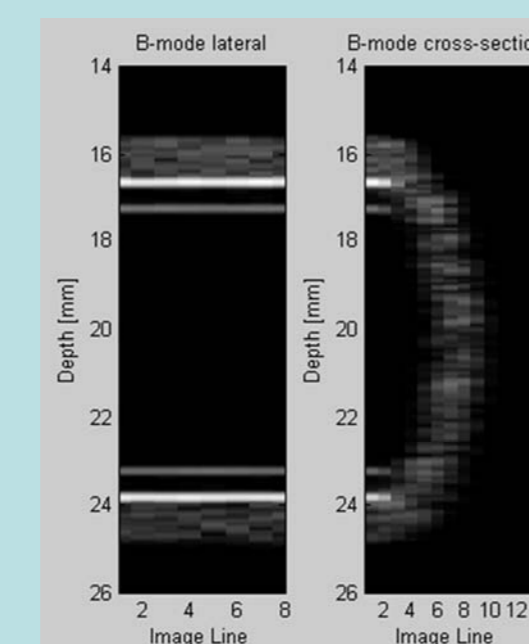
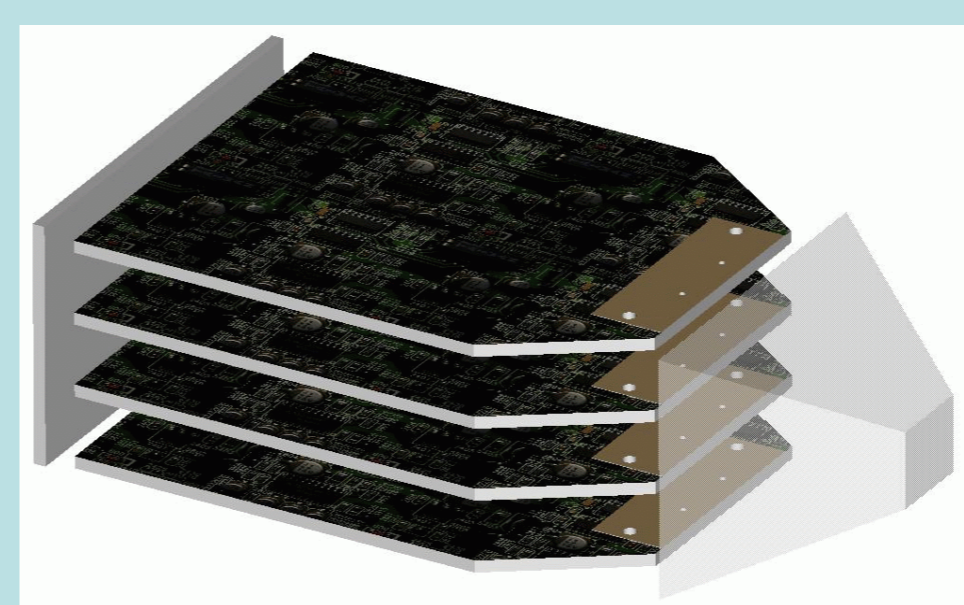

### Beam formation

Both CARIM (Maastricht) and Esaote work on simulations of the beam formation. CARIM researches the dependency of angle between surface and beam, such that the image of a (circular) vessel is independent of the observation angle. Esaote simulated different transmit and receive beams in order to find the fastest mode, which still provides quantifiable images.

### Traditional beam forming vs Plane wave reconstruction

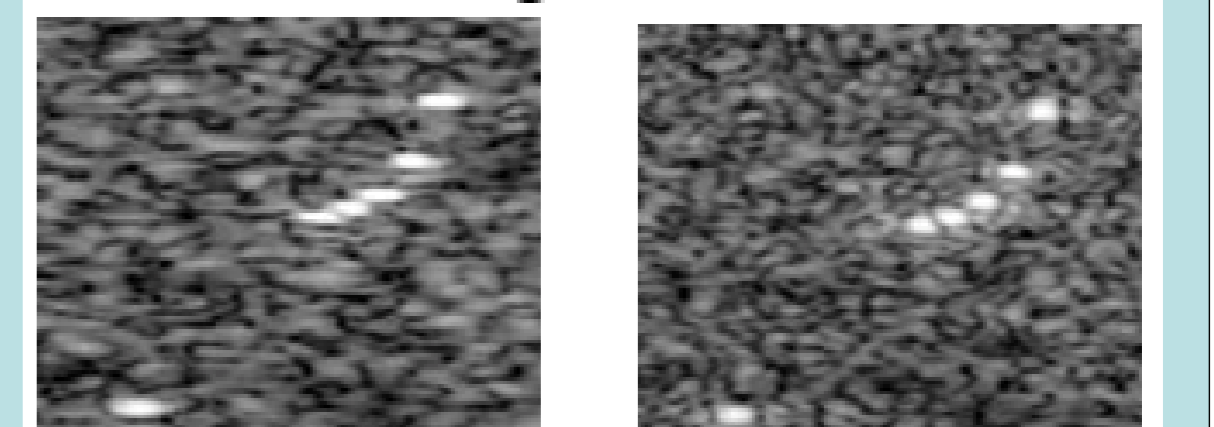

Erasmus MC  
University Medical Center Rotterdam



vermon

esaote

Pie Medical Imaging  
Solutions in Cardiovascular Analysis

HEGP

EURIPIDES  
Eureka Initiative for Packaging & Integration of  $\mu$ Devices & Smart Systems



Contact person: peter.brands@esaote.nl

