

New technological challenges for EV/HEV

—

Christian BALLE

Deputy VP Advanced Electronics Division



**EURIPIDES – Berlin
october 9th**



New technological challenges for EV/HEV

EV/HEV System Architectures

EV/HEV modules

Impact on technologies

**New technological challenges for
EV/HEV**

- q **Soft hybrid**
- q **Mild hybrid**
- q **Full hybrid**
- q **Dual mode**
- q **Electric vehicle**
- q **Fuel Cell vehicle**

Hybrid = 2 power sources

New technological challenges for EV/HEV

Mild Hybrid

ISG

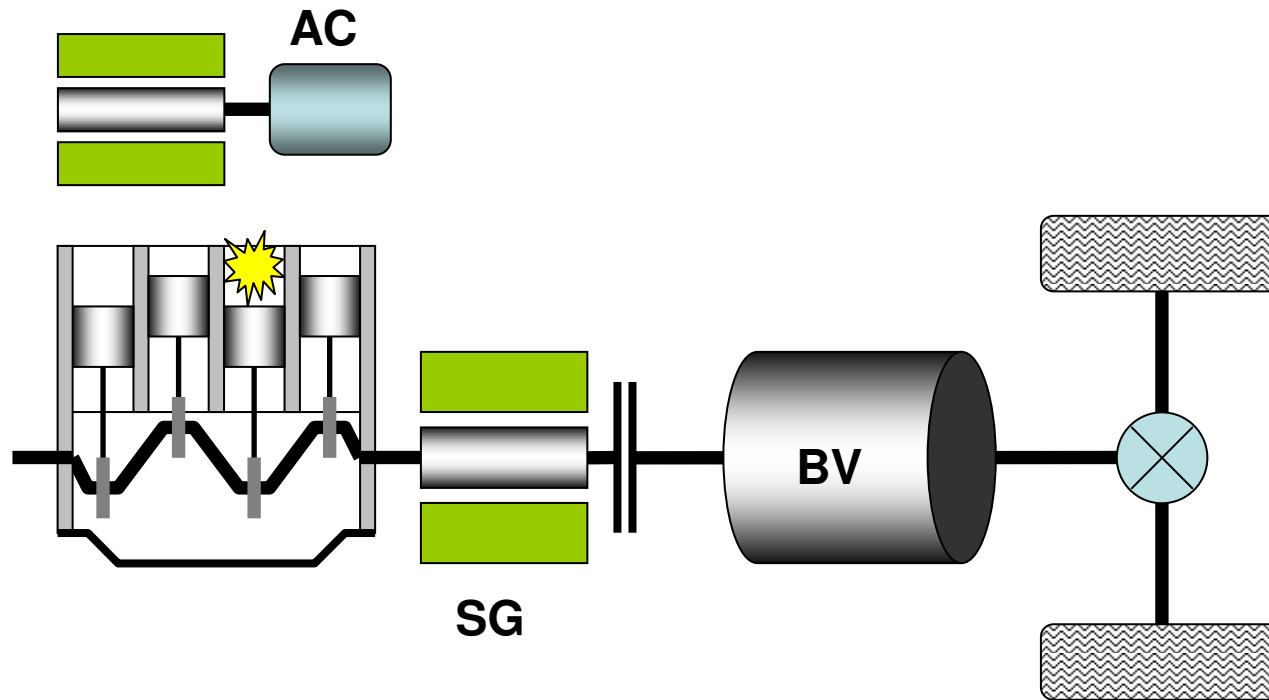



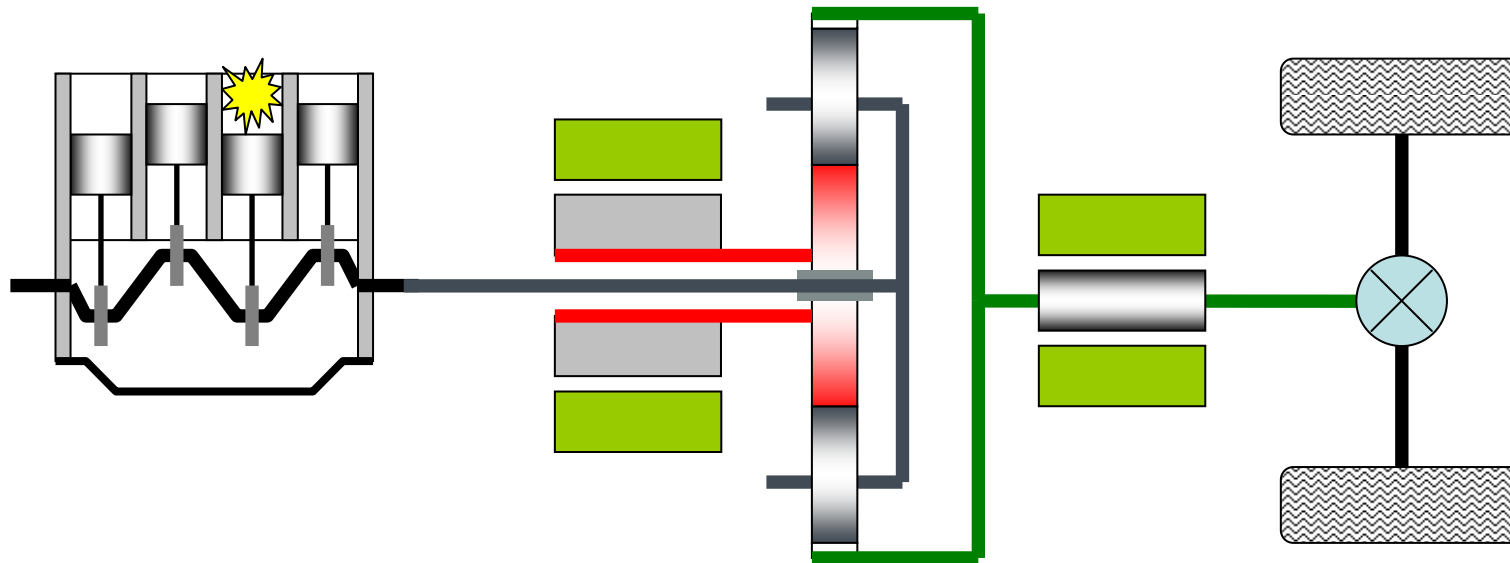

New technological challenges for EV/HEV

Full Hybrid

Dérivation de Puissance (idem Prius)

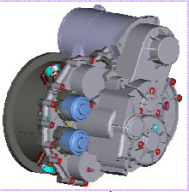

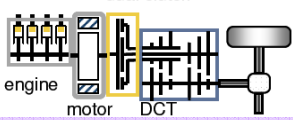
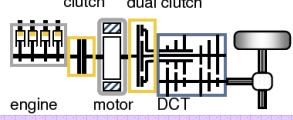
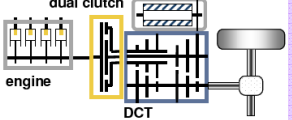
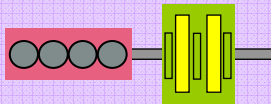
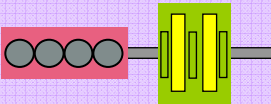
MICRO HEV		MILD HEV		FULL HEV		PLUG-IN HEV	
Level of energy recovery							
Torque assist		Electric drive		Electric drive		Electric drive	
6/8kW / 50V		15kW / 120V		20kW / 200V		50kW / 300V	
Li-ion batt. or supercaps		Li-ion batteries		Li-ion batteries		EV Li-ion batteries	
-10% CO ₂		-15% CO ₂		-20% CO ₂		-25% CO ₂	
SSG : Separated Starter/Generator		IMA (1 motor 1 clutch)		1M2C (1 motor 2 clutches)		DCT + motor	
THS Bi-mode		Bi-mode or 4WP					
PSA C5 concept		Honda Accord/Civic		VW / Mercedes concept		Getrag/Bosch concept	
Toyota Prius		4WP concept					
							
							
							



EV/HEV System Architectures

EV/HEV modules

Impact on technologies

New technological challenges for EV/HEV

Electric Machine(s)

Inverter

DC/DC

Charger

High power industrial motors



Automotive alternators
Starters + Power steering
+ other motors ...

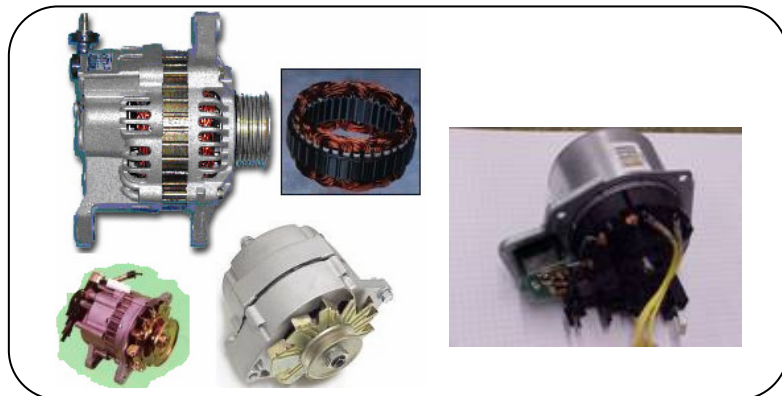

High power automotive motors

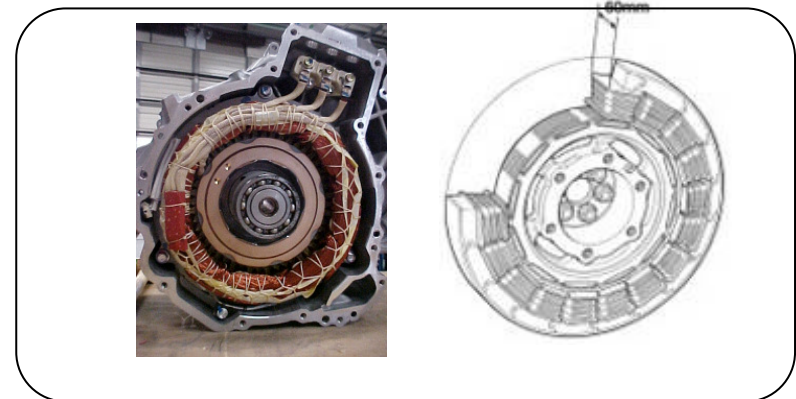

Requires adaptations of :

- Products
- Process
- Materials
- Know-how
- Tests...

- Asynchronous
 - BOSCH
 - SIEMENS
 - CONTINENTAL TEMIC...
- Permanent magnets
 - TOYOTA
 - HONDA
 - AISIN
 - HITACHI...
- Reluctance
 - VISTEON
- Wound rotor
 - VALEO
 - HITACHI
 - DENSO
 - BOSCH

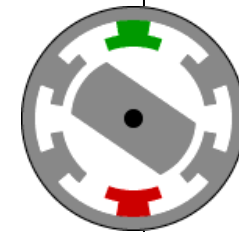
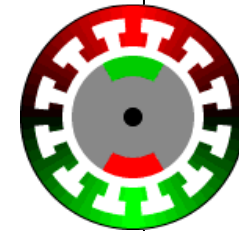
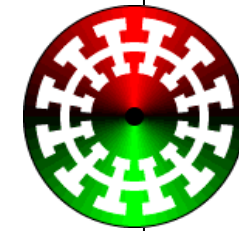

4) Rotor assembly

- MAGNET MOTOR



Magnets

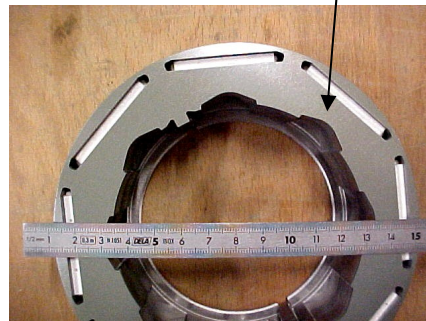

- INDUCTION MOTOR



Aluminum

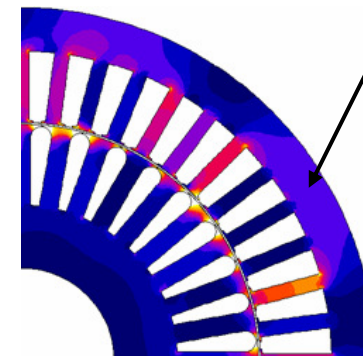

4) Rotor assembly

- SWITCHED RELUCTANCE



- WOUND ROTOR

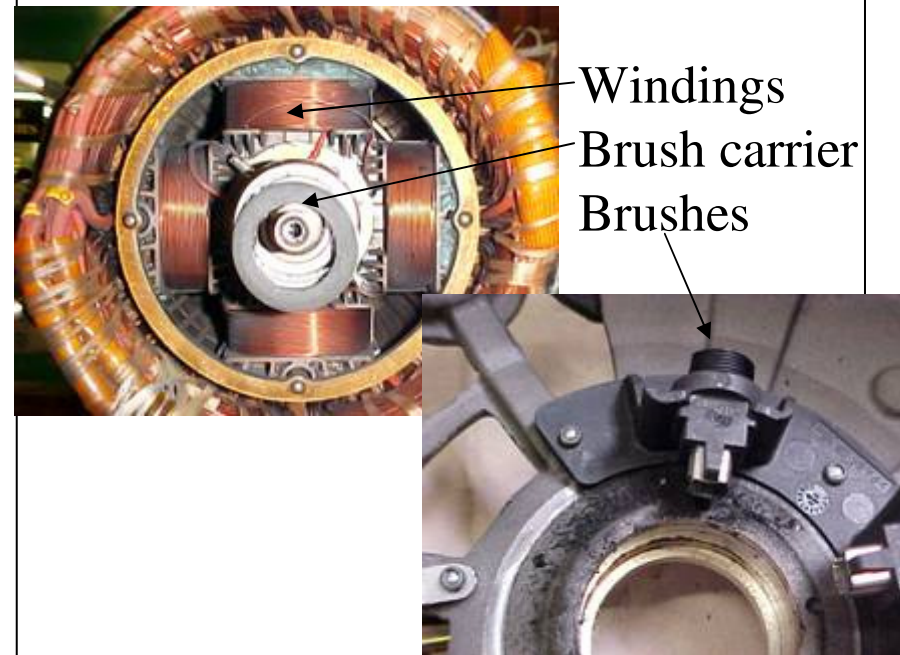

EV/HEV System Architectures

EV/HEV modules

Impact on technologies

Final Overview

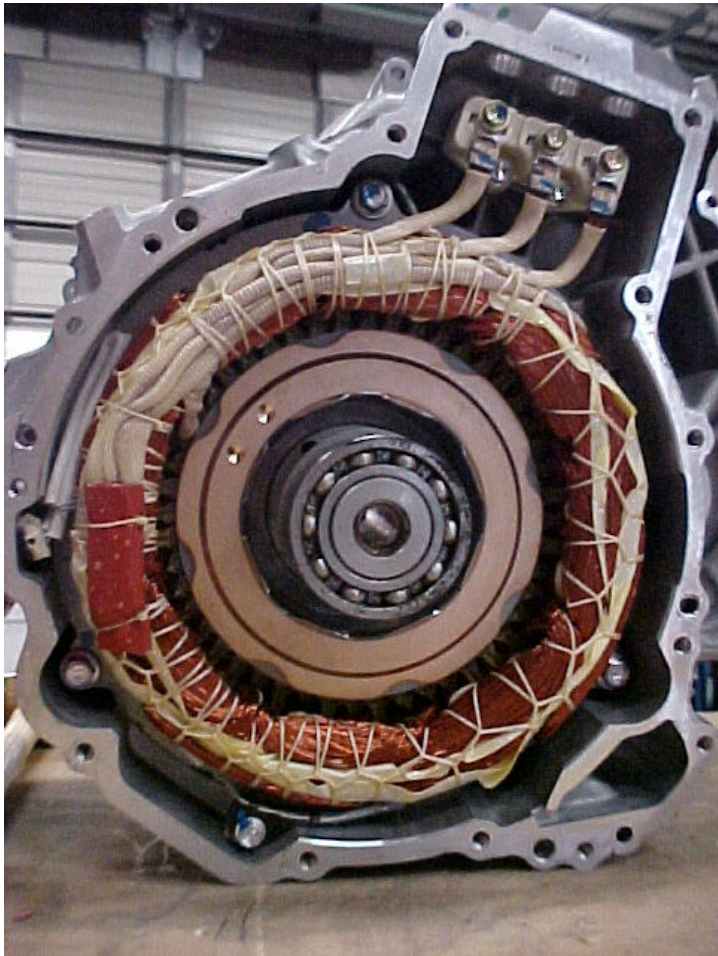

(PRIUS II MOTOR)



STATOR



ROTOR

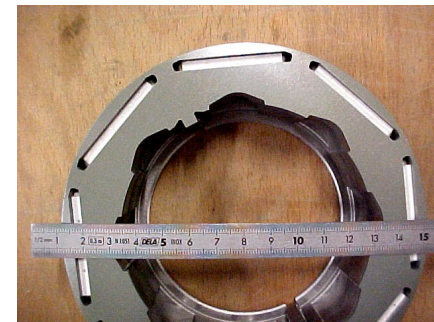

In-Wheel Motor

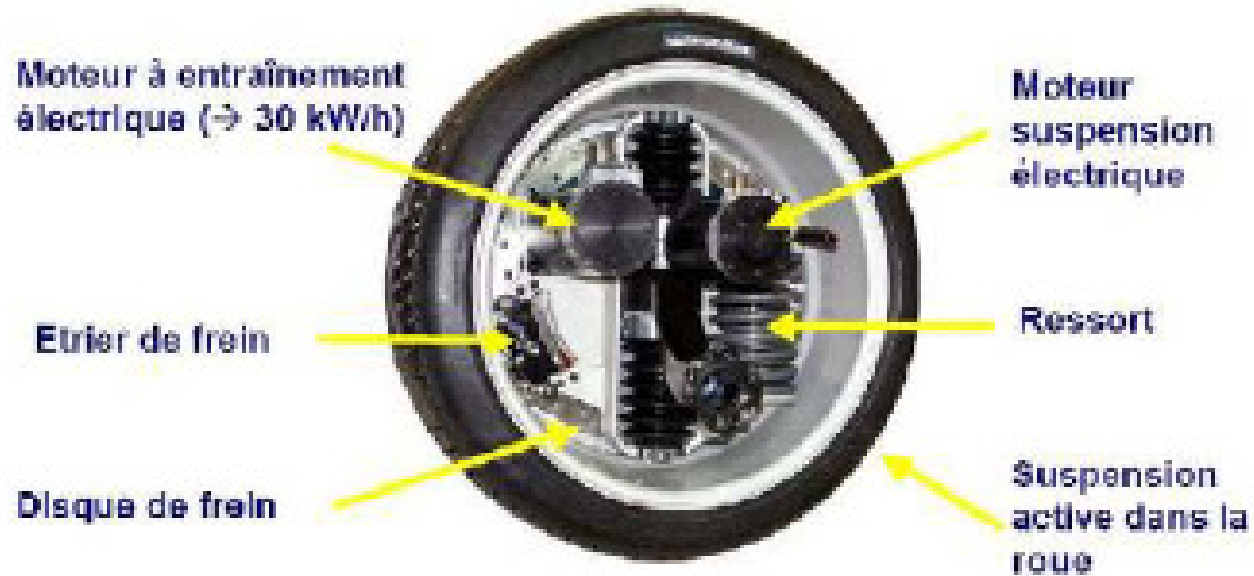

New technological challenges for EV/HEV

Impact on technologies

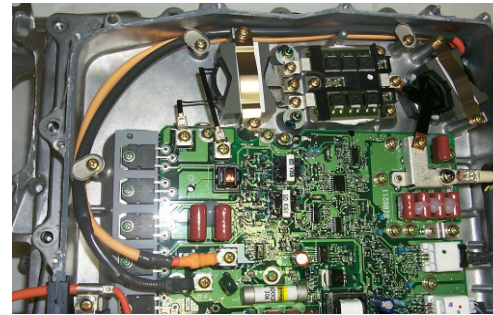
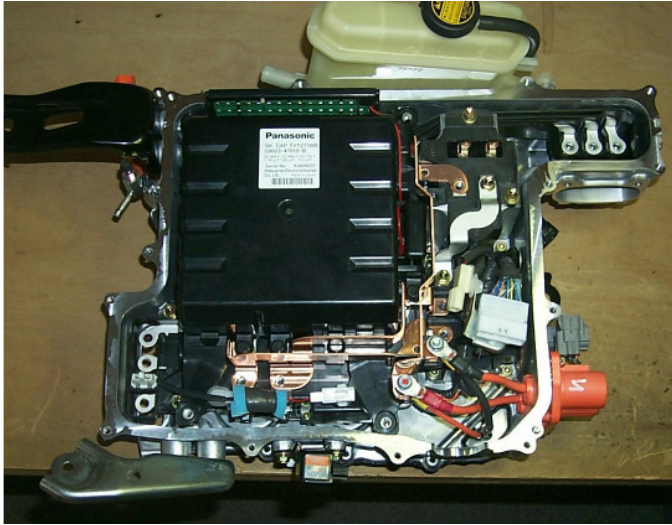

DC/DC 200 V/14 V
⌘ onboard network

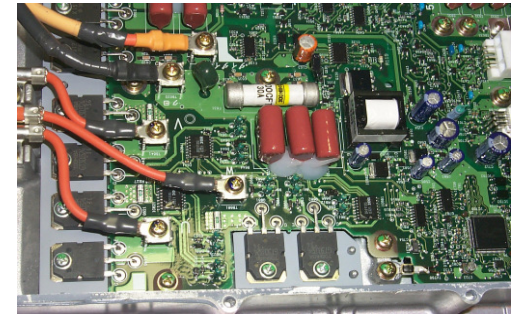

Inverter for AC

Complete package

2 inverters IGBT 800 V

⌘ electric machine

Filtering

DC/DC 200 V/500 V



EV/HEV System Architectures

EV/HEV modules

Impact on technologies

New technological challenges for EV/HEV

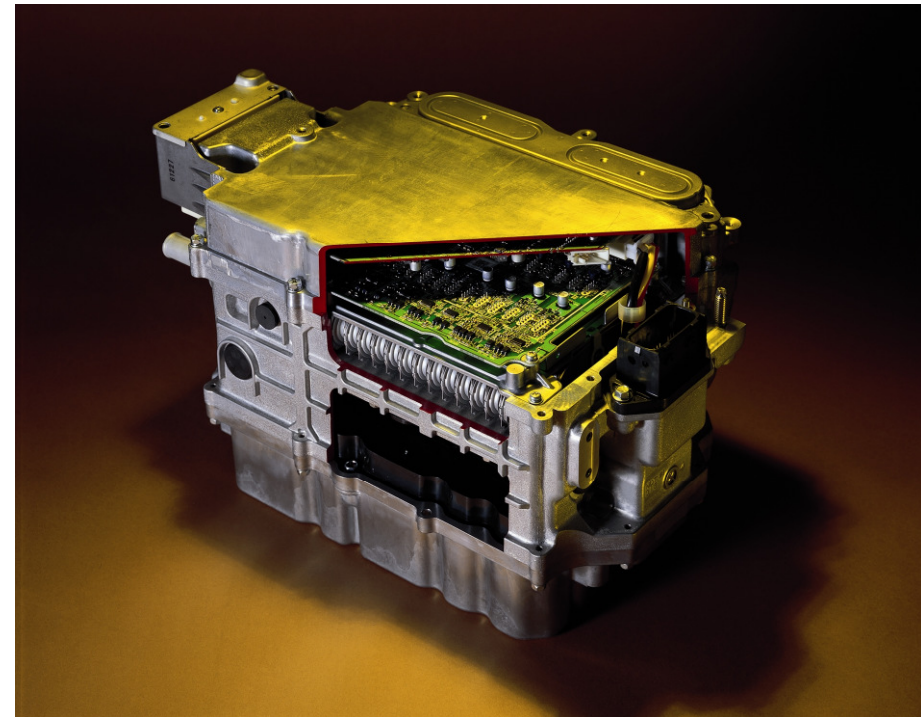
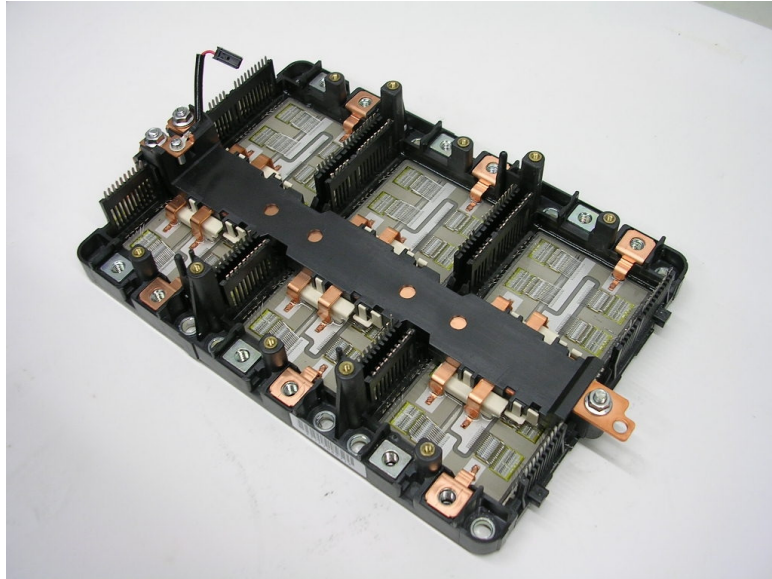

New technological challenges for EV/HEV

Impact on technologies

Photovoltaics on board

- Integration of ~ 1 m² of PV solar pannels on roof, bonnet and trunk of a passenger EV
- Could provide ~ 10% of the car energy with high efficiency cells (20%) if all collected solar energy is used. Practically a few %
- Could be used for desoaking or assistance to AC when the car is under the sun
- Integration easier on the flat roof of a LCV

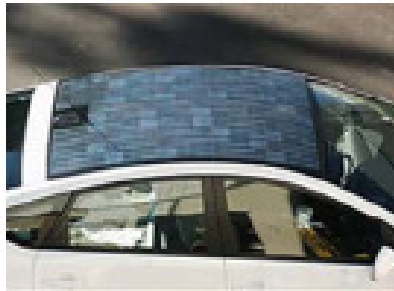

Astrolab venturi

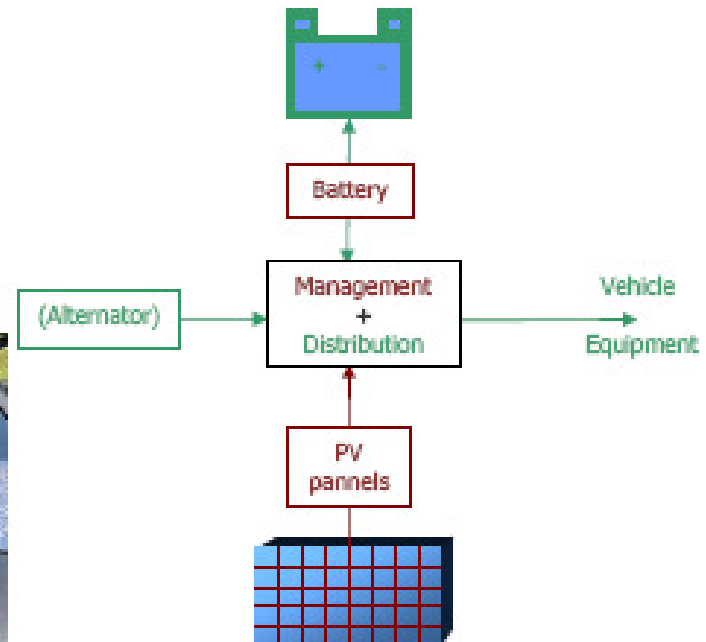

New technological challenges for EV/HEV

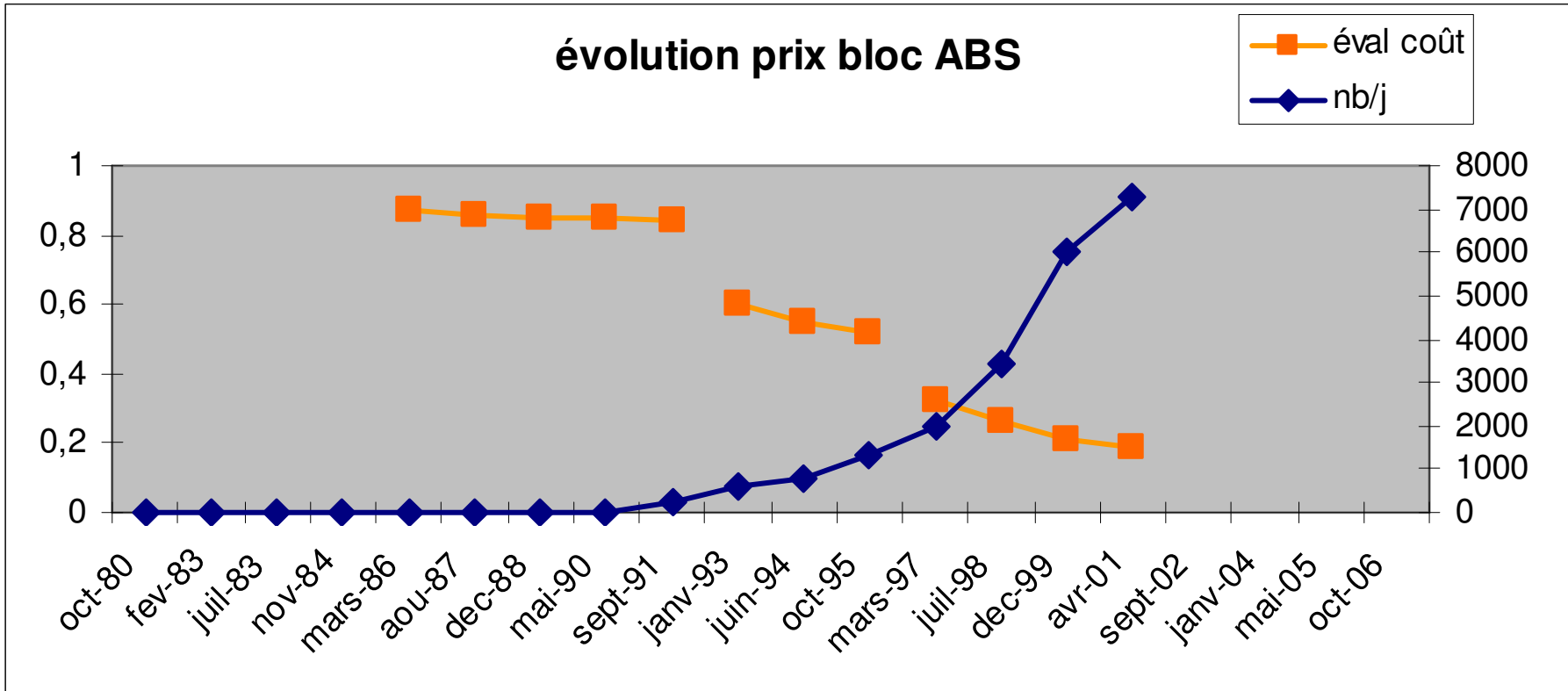

New technological challenges for EV/HEV

“ Power Mechatronics ” trends

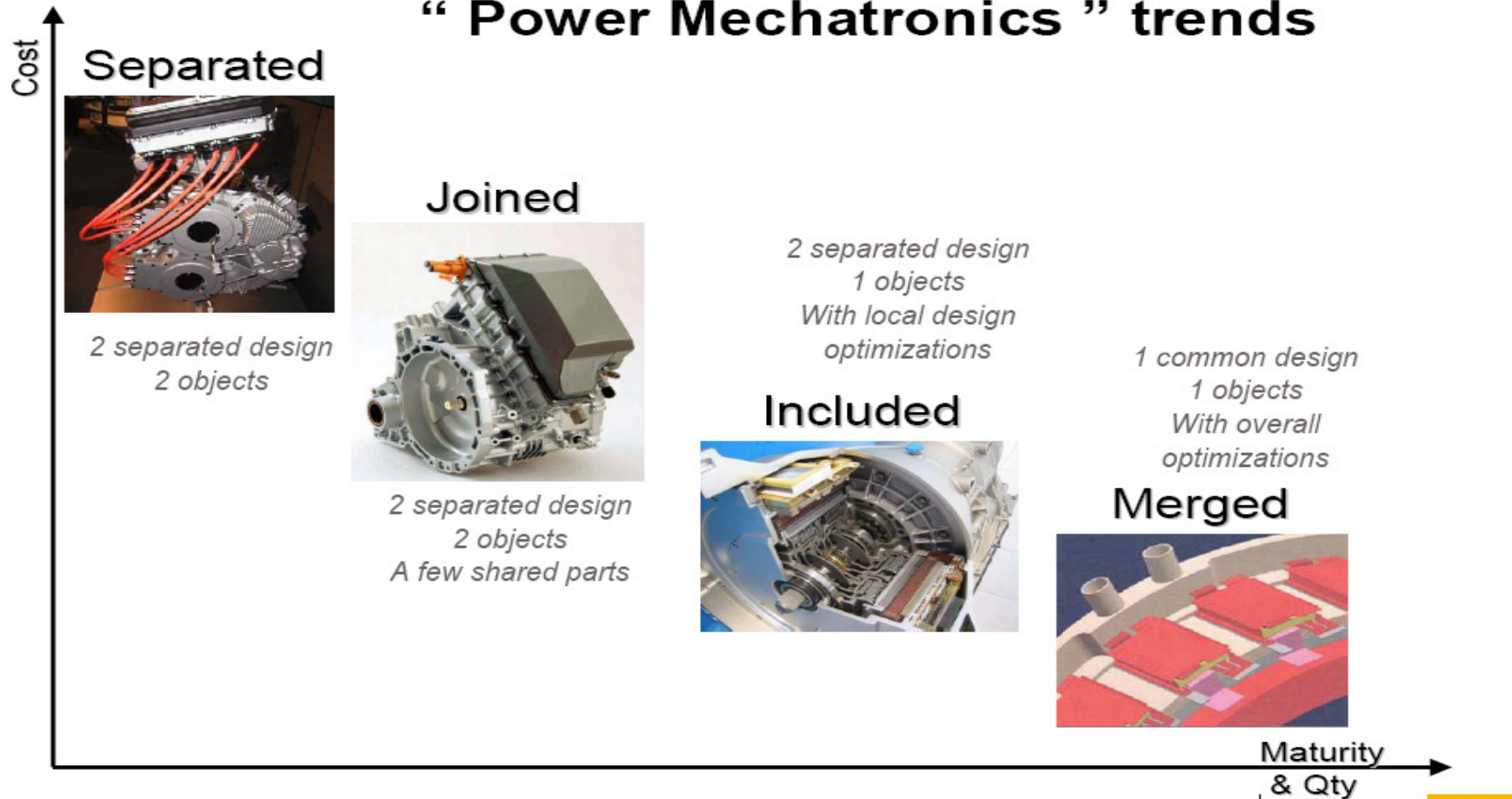

New technological challenges for EV/HEV

CONCLUSION:

New systems

New technologies

New actors

New cooperations

and new competencies